

AST-GPSRF is a high performance, fully integrated GPS RF front-end chip for down conversion and signal amplification. It is designed for GPS L1 (1575.42MHz), C/A and Galileo OS (1575.42MHz) receivers.

- ◆ *Fully integrated GPS and Galileo RF front-end IC*
- ◆ *On-chip LNA, PLL and IF band pass filter*
- ◆ *Digital 2-bit output*
- ◆ *Single 2.7 to 3.3V power supply*
- ◆ *Power down mode supported*
- ◆ *Antenna sensing circuit present on-chip*
- ◆ *Auto-calibrated*



AST-GPSRF is a high performance, fully integrated GPS / Galileo RF front-end chip for down conversion and signal amplification. It is designed for GPS L1 (1575.42MHz), C/A and Galileo OS (1575.42MHz) receivers. It can also process the signals from SBAS satellites.

AST-GPSRF follows a typical super-heterodyne architecture. It has an on-chip LNA as the first block with a typical gain of 20dB and Noise figure of 2dB. This is followed by a single mixer stage which down-converts the input signal frequency to a manageable IF frequency of 4.092MHz. The IF amplifier and band pass filter stages that follow ensure that the IF signal is suitably amplified and filter unwanted out of band interference.

The IF band pass filter stage is uniquely designed and does not require calibration for each and every device. A last stage 2-bit ADC digitizes the IF signal into SIGN and MAG outputs to be interfaced to a GPS Correlator along with the sampling clock. An on-chip PLL accepts a 16.368MHz clock input and derives the mixer frequency.

It is possible to interface either active or passive GPS antenna to AST-GPSRF. In addition, AST-GPSRF also provides features such as GPS antenna open and short detection and protection. AST-GPSRF has an indication of PLL Lock status that can be used to verify the PLL behavior. For power sensitive applications, AST-GPSRF has configurable power down mode, which is selectable by a dedicated pin on the IC.

The IF output before the ADC is brought out to a pin for evaluation / measurement.

AST-GPSRF operates from a single power supply of 2.7 to 3.3V. A typical value of 3.0V is preferred for most applications. At 3.0V, the current drawn is about 15mA.

FUNCTIONAL BLOCK DIAGRAM

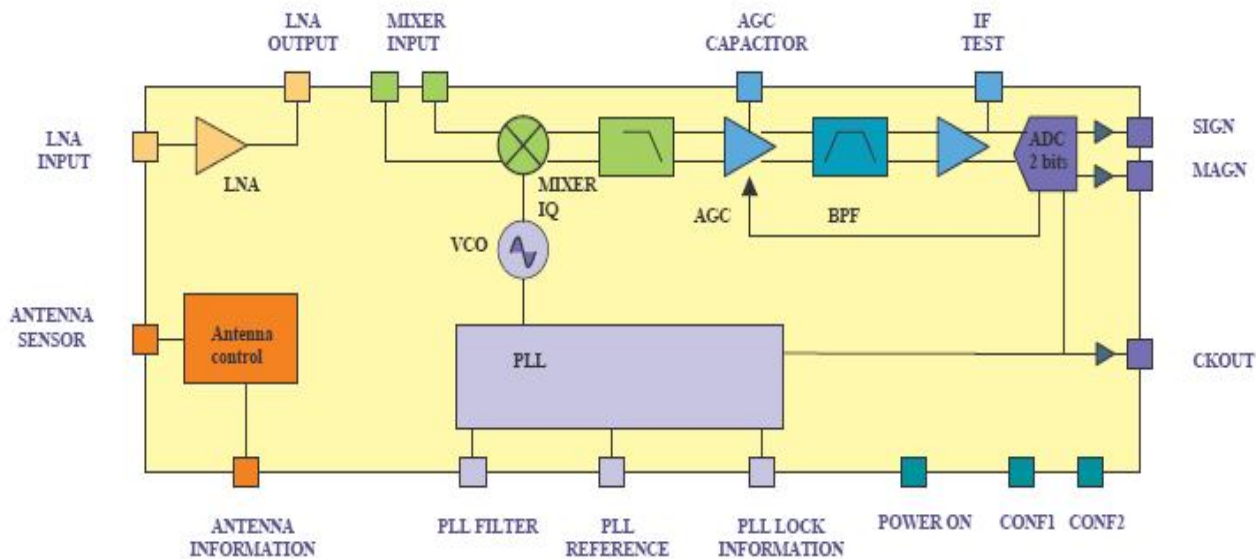

Applications:

- Smartphones and Tablets
- Personal Navigation Devices
- Vehicle Navigation
- Base-station Timing
- Digital Still Camera

NAVIKA

Navika Electronics
51, Goldhill Plaza,
07-10/11,
SINGAPORE 308900

India Office
37, K.R. Colony, Domlur Layout,
Bangalore - 560 071. INDIA.
Tel: +91 - 80 2535 0105
Fax: +91 - 80 2535 2723
Website: www.navika-electronics.com

